



DONG GUAN MAO YUAN ELECTRONICS CO., LTD
东莞茂元电子有限公司

Doggie-Pro Sub-Mini Angel-Iron Processing Machine

FM-30 超小型角铁加工机

可加工75×75×t6mm
不锈钢

Die sets exchange is unnecessary.

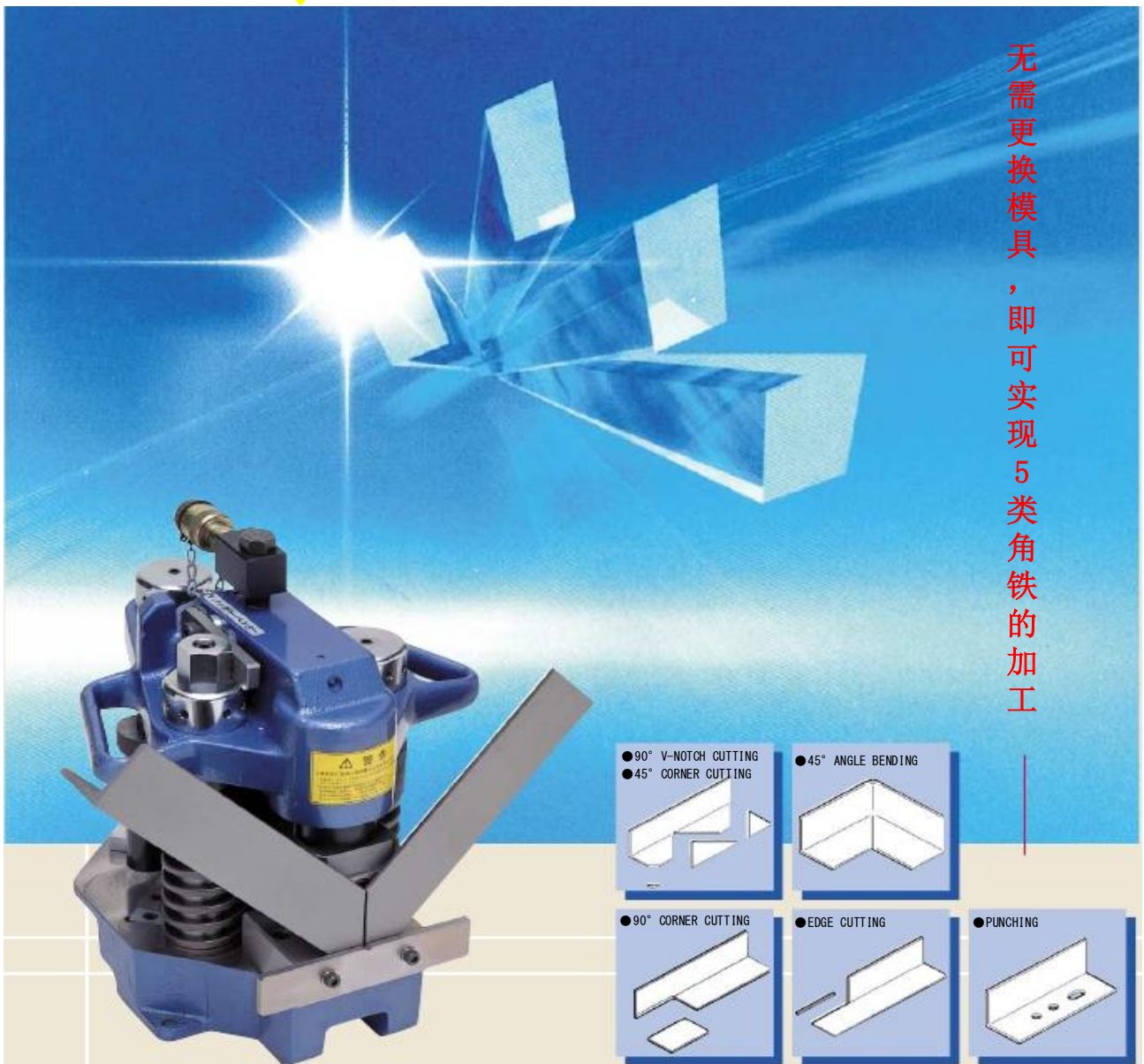

FM-30

无需更换模块、作业性超群 可加工75×75×t6mm不锈钢 小型·高性能加工机

Imagine what the DOGGIE-Pro can do for you.
NITTOH Angel-Iron Processing Machine offer ultimate versatility for angle steel
and / or stainless steel up to 75 x 75 x t6mm for greatly improving productivity.

■同等级别最高加工性能。Max. forming capacity of this class.

只需按标准配置，即可实现不锈钢角铁75 x 75 x t6mm的加工。
Rated at 23 tons. It can handle angle steel or stainless steel up to 75 x 75 x t6mm.

■无需更换模块，即可满足复杂化的加工需求。No need for troublesome exchange of tooling dies.

已含开槽、切角、弯折等模具组合，无需更换模块即可实现各类加工。
V notching / corner cut and bending dies are already incorporated, and there is no need to exchange dies.

■只需切换杠杆，即可轻易实现作业切换。Twin cylinder system with a changeover lever.

因采用双气缸模式，只需切换杠杆，即可实现V开槽、90°·45°切角、弯折等一系列加工。
同时，设置可选冲孔的刀具后，还可实现冲孔作业。
Unlike most competitor units, special changeover lever permits steel forming to be done from V notching or corner cutting to bending, and vice versa much faster and easier than other. Optional punching units only are required to exchange.

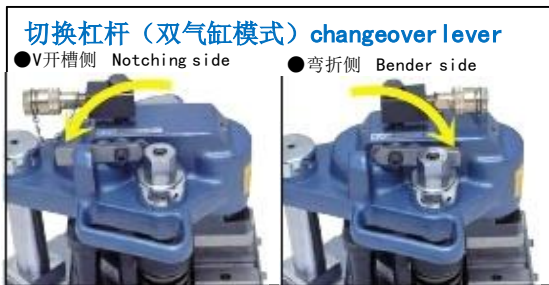

●夹钳模块 Clamp base



■使用夹钳模块，加工位置的校对高效又快捷。Easy positioning with clamp bases.

调整夹钳模块，可轻易校对3mm~6mm用V开槽、90°·45°切角的加工位置。
It is easy to position V notch for 3mm to 6mm, 90° or 45° corner cut by adjusting clamp bases.

■小型·轻量、方便现场作业。Compactness and portability.

主机和油压组为独立套件，可轻松搬运到加工现场。
This versatile forming machine is designed to use with a separated hydraulic pump for portable or fixed applications.

■多类型油压泵，可按需选择。Wide choice of hydraulic pumps.

根据加工频度的高低，可选择高速型油压泵（450W豪华型）、超轻量型油压泵（350W标准型）。
（也可选手提油压组件。但产生压力为70MPa，需和同类型的耦合器搭配使用）
Use with any 70Mpa NITTOH hydraulic pump, UP-45SVG-0.45kw high speed or UP-35RH 0.35kw lightweight and compact type with 2-way solenoid valve and foot-operated switch. Can be used with your pumps on hand having pressure rating of 70MPa.



●高速型油压泵 High speed type pump
(450W豪华型: UP-45SVG-FL)
(Model: UP-45SVG-FL)



●超轻量型油压泵 Super compact pump
(350W标准型: UP-35RH-FL)
(Model: UP-35RH-FL)

标准加工时间	标准型	豪华型
V开槽加工时 (65mm×t6时) Time required Notching of 65×65×t6mm	13秒 UP-35RH-FL 13sec.	7.5秒 UP-45SVG-FL 7.5sec.

■家用100V电压也可使用。Hydraulic pump works on normal power supply 100V.

无需更换模块，即可实行5类角铁的加工

The following 5 kinds of angle forming can be done quickly, without trouble-some exchanging of tooling units

90° V开槽/45° 切角
90° V notching/45° corner cutting

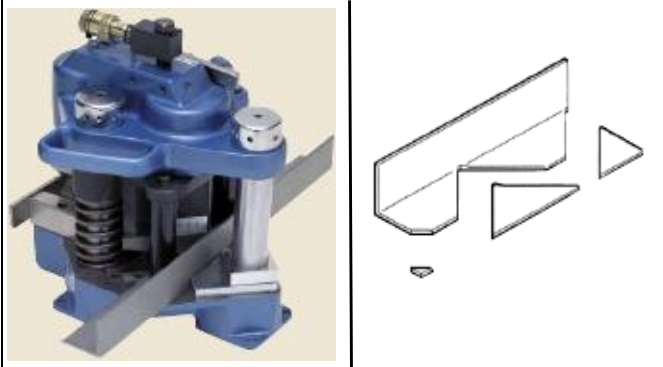

角铁弯折
Angle bending

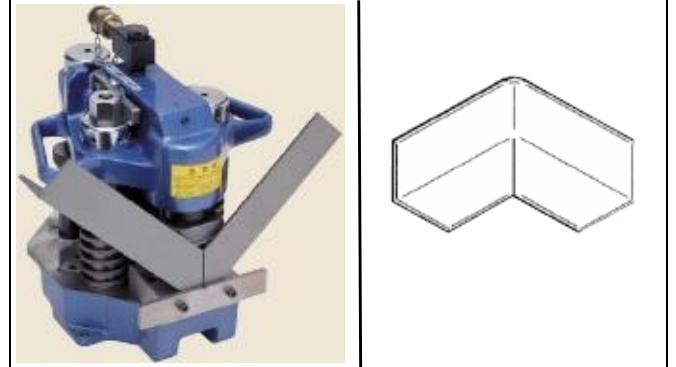

90° 切角
corner cutting

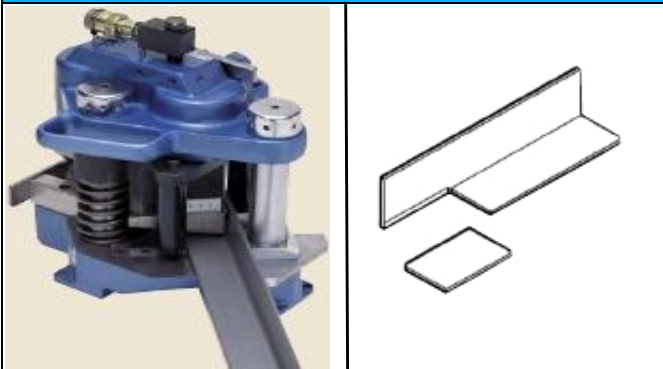

边角裁切
Edge cutting

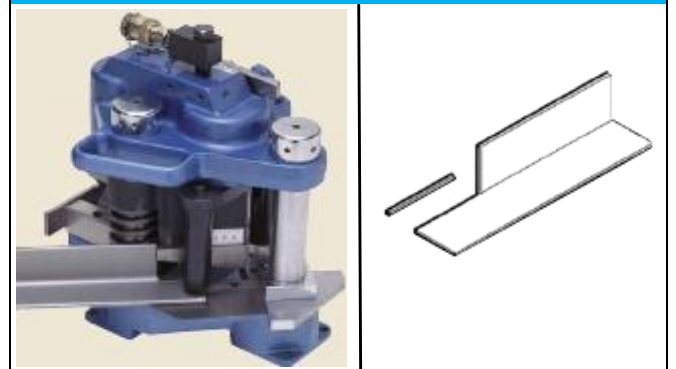

开孔 (可选)
Punching

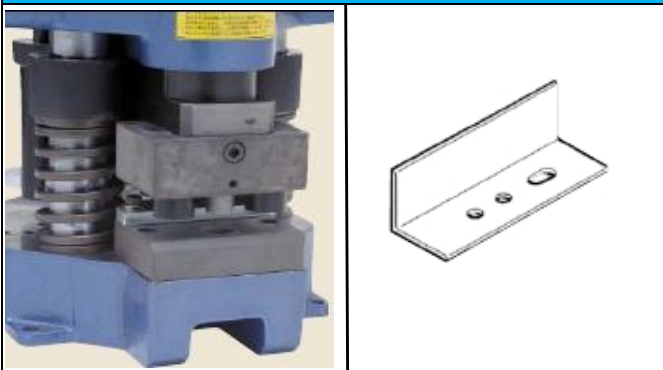

■特别附属品 Optional punching unit

样式 Type	品名
P-75	冲孔底台支架 punching die set
P-11	φ 11mm冲孔底台刀具 punch&die
P-11 (长孔L)	11×16.5mm冲孔底台刀具 oblong punch&die
P-13	φ 13mm冲孔底台刀具 punch&die
P-14	φ 14mm冲孔底台刀具 punch&die
P-14 (长孔L)	14×18mm冲孔底台刀具 oblong punch&die
P-15	φ 15mm冲孔底台刀具 punch&die
P-18	φ 18mm冲孔底台刀具 punch&die

(单位: mm)

■主机尺寸图/规格 Dimensions/Specifications

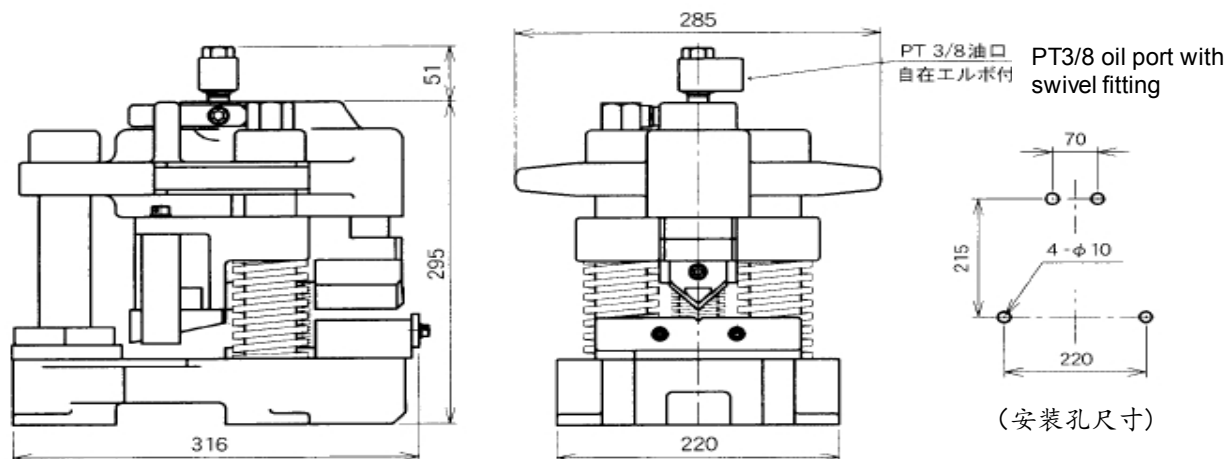

品名 Model	加工能力 Capacity (mm)	油压气缸Single-acting Ram		移动量 stroke (mm)	主机尺寸 Dim (mm)	主机重量 Weight (kg)	标准附属品 Unit componets
		弯折 bending	V开槽 V notching				
FM-30	SS400 SUS304 角铁 steel&stainl ess steel of 75×75×6	170kN	230kN	35	316(L) × 220(W) × 295(H)	50	主机 (V开槽、弯折一体型) 油压组件 Forming unit,hydraulic pump and hose

■油压泵尺寸图/规格 Dimensions/Specifications of pumps

(单位: mm)

●350W标准型 (UP-35RH)

Model UP-35RH-FL

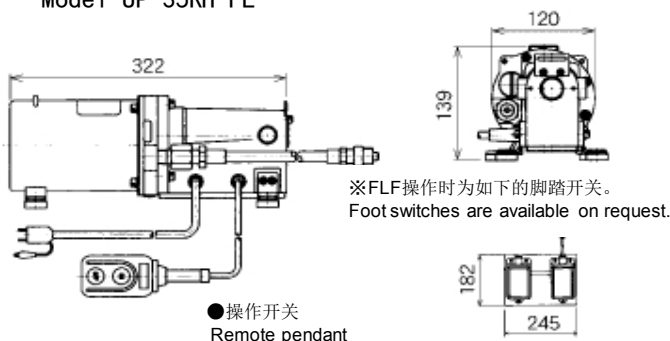

油压压力 pressure rating	70MPa (700kgf/cm ²)
吐出量 Flow rate	低压时: 2.0/min, 高压时: 0.2/min (min/1st stage) (min/2nd stage)
有效油量 Tank usable oil	0.8
马达 Electric motor	100V、350W (50/60Hz)
尺寸 Dimensions	282(L) × 111(W) × 140(H) mm
重量 Weight(with oil)	7.5kg

●450W豪华型 (UP-45SV)

Model UP-45SVG-FL

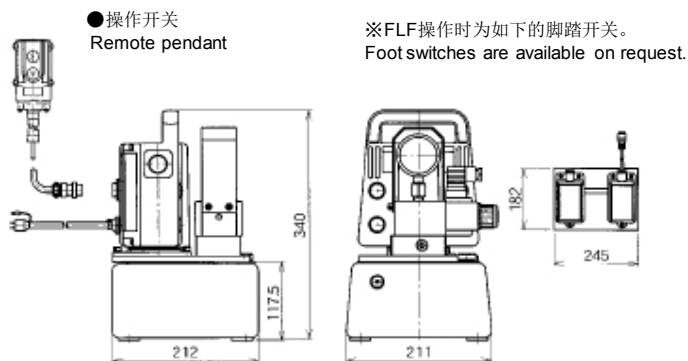

(单位: mm)

油压压力 pressure rating	70MPa (700kgf/cm ²)
吐出量 Flow rate	低压时: 2.5/min, 高压时: 0.35/min (min/1st stage) (min/2nd stage)
有效油量 Tank usable oil	2.0
马达 Electric motor	100V、450W (50/60Hz)
尺寸 Dimensions	212(L) × 212(W) × 340(H) mm
重量 Weight(with oil)	17.2kg

保修期及售后服务

1 保修期

自购买起 1 年。

2 保修范围

保修期内，正常使用下如发生因我司责任而造成的故障，我司可提供免费修理或无偿更换服务。

3 非保修范围

对机器进行误操作、误设定、错误环境下使用等造成的故障、事故及其它损害。

- 未向我司联络、商量，未得到我司允许，私自对机器进行改造。
- 超出机器使用范围、粗暴使用机器，对消耗部品造成磨损、损伤等。
- 与其它装置、设置进行组装使用，非我司原因造成的故障。
- 自然灾害等不可抗力造成的故障。
- 火灾、水淹、坠地等事故对机器造成的损害。
- 因制造设备等事故造成其它物品(我司以外机器)的损害。



东莞茂元电子有限公司

地址：广东省东莞市常平镇桥沥北门村

电话：0769-82206100 传真：0769-82206300

Website: <http://www.nittoh-changping.com/>